

Cuisinart®

Espresso Defined™

INSTRUCTION
BOOKLET



Fully Automatic Espresso Machine

EM-1000

For your safety and continued enjoyment of this product, always read the instruction book carefully before using

IMPORTANT SAFEGUARDS

When using electrical appliances, basic safety precautions should always be followed to reduce the risk of fire, electric shock and/or injury to persons, including the following:

1. **READ ALL INSTRUCTIONS.**
2. **Always unplug from outlet when not in use and before cleaning. Allow to cool before putting on or taking off parts and before cleaning the appliance.**
3. Do not touch hot surfaces. Use handles and knobs.
4. To protect against fire, electric shock and injury to persons do not immerse cord, plugs, or base unit in water or other liquid.
5. Close supervision is necessary when any appliance is used by or near children.
6. Do not operate any appliance with a damaged cord or plug or after the appliance malfunctions or has been dropped or damaged in any manner. Return appliance to the nearest Cuisinart Repair Center for examination, repair, or electrical or mechanical adjustment.
7. An extension cord is not recommended. However, if one is needed, the extension cord should be a grounded type and its electrical rating must be the same or higher wattage as the appliance. Regularly inspect the supply cord, plug and actual appliance for any damage.
8. Do not use this appliance for anything other than its intended use. Do not use in moving vehicles or boats.
9. The use of accessory attachments not recommended by Cuisinart may result in fire, electric shock or injury to persons.
10. Scalding may occur if the lid is removed during brewing cycles.
11. Do not use outdoors.
12. Do not leave the appliance unattended when in use.
13. Do not let cord hang over edge of table or counter, or touch hot surfaces.
14. Always use the appliance on a dry, level surface.
15. Do not place on or near a hot gas or electric burner, or in a heated oven.

IMPORTANT SAFEGUARDS

16. Always fill water reservoir first, then plug cord into the wall outlet. To disconnect, turn controls to OFF, then remove plug from wall outlet.
17. Never use the machine without water in it.
18. Use only cold water in the water reservoir. Do not use any other liquid.
19. Refer servicing to qualified personnel.
20. Avoid contact with moving parts.
21. Always switch the appliance off, and then remove plug from the power outlet when the appliance is not being used and before cleaning.
22. Allow to cool before putting on or taking off parts, and before cleaning the appliance.
23. Strictly follow cleaning and care instructions.
24. Do not clean drip tray with cleansers, steel wool pads, or other abrasive materials.
25. **WARNING: TO REDUCE THE RISK OF FIRE OR ELECTRIC SHOCK, DO NOT REMOVE THE BASE PANEL. NO USER-SERVICEABLE PARTS ARE INSIDE. REPAIR SHOULD BE DONE ONLY BY AUTHORIZED PERSONNEL.**
26. Do not operate your appliance in an appliance garage or under a wall cabinet. When storing in an appliance garage, always unplug the unit from the electrical outlet. Not doing so could create a risk of fire, especially if the appliance touches the walls of the garage or the door touches the unit as it closes.

SAVE THESE INSTRUCTIONS

FOR HOUSEHOLD USE ONLY

Safeguards

WARNING: RISK OF FIRE OR ELECTRIC SHOCK



The lightning flash with arrowhead symbol within an equilateral triangle is intended to alert the user to the presence of uninsulated dangerous voltage within the product's enclosure that may be of sufficient magnitude to constitute a risk of fire or electric shock to persons.



The exclamation point within an equilateral triangle is intended to alert the user to the presence of important operating and maintenance (servicing) instructions in the literature accompanying the appliance.

SPECIAL CORD SET INSTRUCTIONS

A short power-supply cord is provided to reduce the risks resulting from becoming entangled in or tripping over a longer cord. Extension cords may be used if care is exercised in their use.

If an extension cord is used, the marked electrical rating of the extension cord must be at least as great as the electrical rating of the appliance, and the longer cord should be arranged so that it will not drape over the countertop or tabletop where it can be pulled on by children or tripped over.

NOTICE

This appliance has a polarized plug (one blade is wider than the other). To reduce the risk of electric shock, this plug will fit in a polarized outlet only one way. If the plug does not fit fully in the outlet, reverse the plug. If it still does not fit, contact a qualified electrician. Do not modify the plug in any way.



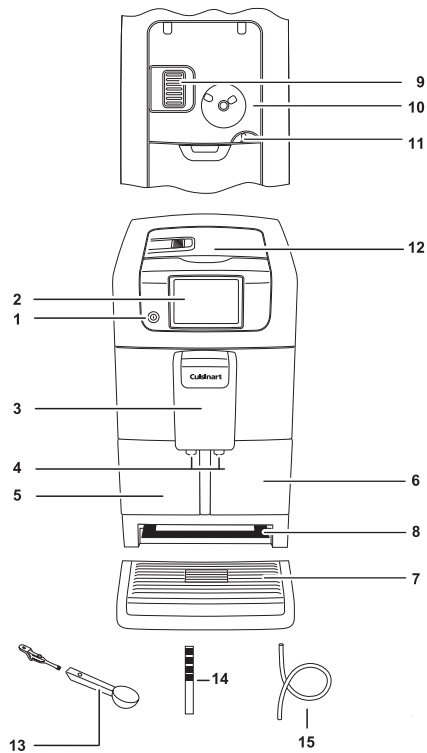

































Coffee machine/operating elements

- 1) ON/OFF button
- 2) Multifunction display with touch operation
- 3) Height-adjustable dispenser with integrated milk outlet
- 4) Coffee spout
- 5) Waste container (Grounds container)
- 6) Water tank
- 7) Removable drip tray with stainless steel grid
- 8) Built in quick start guide
- 9) Ground coffee chamber for previously ground coffee
- 10) Coffee bean hopper / container
- 11) Lever for setting the grinding fineness
- 12) Cover for bean container
- 13) Measuring spoon with cleaning brush and tool function
- 14) Test strip for determining the water hardness
- 15) Milk tube

Coffee machine/operating elements

Symbols						
Product selection		Coffee		Espresso		Cappuccino
		Latte Macchiato		Hot milk/ Frothed milk		Hot water
		Carafe of coffee ' (via coffee preparation menu)		Free storage space (M1 - 4)		Allocated storage space M1 - 4; call saved settings
Operating elements		Select drink left		Select drink right		Save as basic setting
		Prepare 1 cup		Prepare 2 cups		Prepare carafe
		Change ground coffee quantity		Heat up (only information)		Select coffee grounds
		Increase quantity		Reduce quantity		Current quantity
		Confirm selection		Cancel process		Back one menu level
Settings menu		Call up settings menu		Coffee temperature		Ecomode Heating system
		Information		Shut-off time		Water tank illumination
		Water hardness		Default settings		Start milk cleaning system
		Run cleaning program		Start descaling program		Back one menu level

Delivery contents:

- Automatic coffee maker
- Milk tube
- Measuring spoon with cleaning brush and tool function
- Test strip for determining the water hardness
- Drip tray with stainless steel sieve
- User manual
- Quick guide (as plug-in card in the coffee machine)

Conair Corporation

One Cummings Point Road
Stamford, CT 06902

Phone 1-800-726-0190

Table of Contents

1 Foreword	10
2 General	10
2.1 Information on this user manual	10
2.2 Copyright	10
2.3 Warnings	11
2.4 Intended use	12
2.5 Limitation of liability	12
2.6 Customer service	13
3 Safety	14
3.1 Danger of electric current	14
3.2 Danger of burning or scalding	14
3.3 Fundamental safety precautions	15
4 Putting into operation	17
4.1 Requirements for place of operation	17
4.2 Electrical connection	17
4.3 Mounting the drip tray	18
4.4 Connecting the milk system	18
4.5 Filling with water	20
4.6 Filling the coffee bean container	21
5 Screen display with pressure-sensitive input area	22
5.1 Main menu	22
5.2 Settings menu	24
5.3 Product symbols	25
5.4 Graphical symbols	26
5.5 Requirements on the user	27
6 Operation and use	28
6.1 Safety precautions	28
6.2 Switching on the coffee machine	29
6.3 Switching off the coffee machine	30
6.4 Switching off the coffee machine in an emergency	31
6.5 Determining the water hardness	31
6.6 Setting and saving the water hardness level	32
6.7 Setting the grinding fineness	33
6.8 Changing the grinding quantity	34
6.9 Changing and storing the cup filling level	35
6.10 Changing and saving brewing settings	35
6.11 Changing a drink setting during selection	37
6.12 Milk system cleaning	37

Table of Contents

6.13 Setting and storing the coffee temperature.....	39
6.14 Select heating mode.....	40
6.15 Setting and storing the shut-off time.....	41
6.16 Setting the water tank illumination.....	42
6.17 Resetting the coffee machine to the factory settings (Reset).....	43
6.18 Display number of dispensed coffees (info menu).....	44
6.19 Preparing coffee with whole coffee beans.....	45
6.20 Coffee can function.....	46
6.21 Preparing coffee with coffee grounds.....	48
6.22 Hot water preparation.....	50
6.23 Preparing coffee specialities.....	51
7 Cleaning and maintenance	55
7.1 Safety precautions	55
7.2 Regular cleaning.....	56
7.3 Milk system cleaning program.....	56
7.4 Emptying the waste container	58
7.5 Removing and cleaning the coffee dispensing unit.....	59
7.6 Cleaning the hose distribution system.....	60
7.7 Installing the coffee dispensing unit.....	61
7.8 Cleaning the brewing unit.....	62
7.9 Running the cleaning program.....	65
7.10 Running the descaling program	66
7.11 Cleaning the nozzle of the milk frother	69
8 Troubleshooting	72
8.1 Safety precautions	72
8.2 Coffee machine messages, possible causes and remedies	73
8.3 Problems, possible causes and remedies	76
8.4 Proper packing of the coffee machine	79
9 Storage.....	80
10 Disposal.....	80
10.1 Disposal of the packaging	80
11 Appendix	81
11.1 Technical data	81
11.2 Warranty.....	82

1 Foreword

Dear Customer,

By purchasing this automatic coffee machine, you have decided in favour of a quality product that meets the latest development standards with respect to engineering and function.

Please read the information contained in this user manual to familiarise yourself quickly with the coffee machine and be able to make full use of its functions.

Your coffee machine will serve your needs for many years to come provided you handle and maintain it with due care.

We wish you a lot of pleasure with the coffee machine.

2 General

2.1 Information on this user manual

This user manual is part of the Model EM-1000 automatic coffee machine (hereafter referred to as the coffee machine) and provides you with important instructions on setting up, safety, intended use and maintenance of the coffee machine.

The user manual must be kept close to the system at all times. It must be read and observed by every person entrusted with operating, troubleshooting and/or cleaning/descaling of the coffee machine.

Keep this user manual in a safe place and pass it to any future owners on with the device.

2.2 Copyright

This document is protected by copyright.

Any duplication or reprinting, in whole or in part, and the reproduction of the illustrations even in modified form is only permitted with the written approval of the manufacturer.

2.3 Warnings

The following warnings are used in this user manual:

DANGER

A warning of this category indicates a potentially dangerous situation.

If the dangerous situation is not avoided, it may lead to serious injury or even fatal injury. (e.g., electric shock).

- ▶ It is therefore imperative that you follow the instructions in this warning in order to avoid personal injury.

WARNING

A warning of this category indicates a potentially dangerous situation.

If the dangerous situation is not avoided, it may lead to injuries (e.g., burns).

- ▶ Follow the instructions in the warning to prevent injuries.

CAUTION

A warning of this category indicates potential material damage.

If the situation is not avoided, it may lead to material damage (e.g. defective coffee machine).

- ▶ Follow the instructions in the warning to prevent damage.

NOTE

- ▶ A note indicates additional information that simplifies the use of the coffee machine.

2.4 Intended use

The fully automatic coffee machine Cuisinart EM-1000 is intended for use in homes and similar applications, for instance in staff kitchens, shops, offices and similar areas or by customers in bed & breakfast, hotels, motels and other living accommodation. **This coffee machine is not intended for commercial use.** The machine is only intended for preparing coffee and heating milk and water. Any other use other than previously stated is considered as improper use.

WARNING

Danger resulting from improper use!

If not used for its intended purpose or used in any other way, the coffee machine may be or become a source of danger.

- ▶ Therefore, the coffee machine may only be used for its intended purpose.
- ▶ Observe the procedures described in this user manual.

No claims of any kind will be accepted for damage or injury resulting from use of the coffee machine for other than its intended purpose.

The risk has to be borne solely by the machine owner.

2.5 Limitation of liability

All technical information, data and instructions on installation, operation and maintenance of the coffee machine contained in these operating instructions represent the current status at the time of printing and are based on the best possible knowledge gained by experience and know-how.

No claims can be derived from the information, illustrations and descriptions in this user manual.

The manufacturer assumes no liability for damage or injury resulting from failure to observe the user manual, use for other than the intended purpose, unprofessional repairs, unauthorised modifications or use of non-approved spare parts.

2.6 Customer service

For initial contact in the event of questions, complaints or repairs we have set up a service hotline for you.

NOTE

The free service hotline number
1-800-726-0190

Experience has shown that well over half of all complaints on automatic coffee machines from customers are attributed to operating errors. Please take the opportunity to obtain quick and easy assistance from our service hotline.

Call the service hotline and save yourself the hassle of transporting your coffee machine to your retailer.

Please note that the coffee machine can only be transported safely in the original packaging.

If the coffee machine is not packed correctly, the customer must bear the liability for any damage caused during transport. You should therefore keep the original packaging. Information on how to correctly pack the appliance can be found in Chapter **8.4 *Proper packing of the coffee machine.***

3 Safety

This section contains important safety instructions for handling the coffee machine. This coffee machine complies with the prescribed safety regulations. Improper use can however result in personal injury and/or coffee machine damage.

3.1 Danger of electric current

DANGER

Danger to life by electric current!

Contact with live wires or components could lead to serious injury or even death!

Observe the following safety precautions to avoid electric shocks:

- ▶ Do not use the coffee machine if the connecting cable or mains plug are damaged.
- ▶ Before reusing the coffee machine, the power cord must be renewed by a qualified electrician.
- ▶ Do not open the housing of the coffee machine. Danger of electric shock if live connections are touched and/or the electrical and mechanical configuration is changed.

DANGER

Danger from rotating coffee mill!

- ▶ Before cleaning the bean container, pull the mains plug of the appliance out of the socket.

3.2 Danger of burning or scalding

WARNING

Parts of the coffee machine can become very hot during operation! Dispensed drinks and escaping steam are very hot!

Observe the following safety precautions to avoid burning/scalding yourself and/or others:

- ▶ Do not touch either of the metal sleeves on both coffee spouts.
- ▶ Avoid direct contact of the skin with escaping steam or hot rinsing, cleaning and descaling water.

3.3 Fundamental safety precautions

NOTE

Observe the following safety precautions to ensure safe handling of the coffee machine:

- ▶ Never play with packaging material. Risk of suffocation.
- ▶ Inspect the coffee machine for visible signs of damage before use. Do not use a damaged coffee machine.
- ▶ If the connecting cable is damaged, it should only be replaced by a service agent recommended by the manufacturer in order to prevent any danger! Please contact the manufacturer or his customer service.
- ▶ Repairs to the coffee machine during the warranty period may only be carried out by service centres authorised by the manufacturer, otherwise the warranty will become void in the event of subsequent damage.
- ▶ Defective parts may only be replaced with original spare parts. Only original spare parts guarantee that the safety requirements are met.
- ▶ This appliance can be used by children from the age of 8 up as well as by persons with reduced physical, sensory or mental abilities or with lacking experience and/or knowledge, if these persons are supervised or have been instructed how to use the appliance in a safe way and have understood the hazards which could arise from using it. Children must not play with the appliance. Cleaning and user maintenance must not be carried out by children unless they are supervised.
- ▶ This appliance is intended to be used in household and similar applications such as:
 - staff kitchen areas in shops, offices and other working environments
 - farm houses
 - by clients in hotels, motels and other residential type environments
 - bed and breakfast type environments
- ▶ Protect the coffee machine against the effects of weather such as rain, frost and direct sunlight. Do not use the coffee machine outdoors.

NOTE

- ▶ Never immerse the coffee machine itself, the power cord or the mains plug into water or other liquids.
- ▶ Do not clean the coffee machine or accessories in a dish washer.
- ▶ Do not pour any other liquids apart from water or place foodstuffs into the water tank.
- ▶ Do not fill the water tank beyond the maximum mark (lower edge of the filling hole) (1.4 litres).
- ▶ Only operate the machine when the waste container, drip tray and the cup grate are fitted.
- ▶ Do not pull the cable to remove the plug from the mains socket or touch with wet hands.
- ▶ Do not hold the coffee machine with the power cord.
- ▶ Keep the appliance and its cord out of reach of children aged less than 8 years.

4 Putting into operation

4.1 Requirements for place of operation

For safe and trouble-free operation of the coffee machine, the place of operation must satisfy the following requirements:

- Place the coffee machine on a fixed horizontal, heat-resistant and water-resistant surface that is strong enough to hold it.
- Select the installation- and connection location out of reach of children.
- The coffee machine is not intended for installation in enclosed spaces such as an appliance garage.
- The plug socket must be easily accessible so that the power cord can be easily pulled out in an emergency.
- In order to assume a fault-free operation, the ambient temperature should be between 46 ° F and 104 ° F.

NOTE

- ▶ When the appliance has cooled under 32 ° F, the appliance temperature must reach an area within the recommended ambient temperature, before switching on the appliance once again.

4.2 Electrical connection

For safe and trouble-free operation of the coffee machine, the following instructions on electrical connection must be observed:

- Before connecting the coffee machine, compare the connection data (voltage and frequency) on the rating plate with those of your power supply. This data must correspond in order to avoid damage to the coffee machine. If in doubt, consult a qualified electrician.
- The socket must be secured at least 13 Amp. fuse breaker. Ensure that the connecting cable is undamaged and is not laid over hot surfaces or sharp edges.
- Connection of the power supply via an extension cable must not exceed a length of 9 feet and 13 Amp. rating. For fire prevention reasons, the use of multiple adapters or power outlet strips is forbidden.
- The connecting cable must not be pulled tight.
- The electrical safety of the coffee machine is only assured when it is connected to a properly installed grounded ground. Connection to a socket without conductor is forbidden. If in doubt, the electrical system must be checked by a qualified electrician. The manufacturer assumes no liability for injury or damage caused by a missing or interrupted protective earth conductor.

4.3 Mounting the drip tray

- ◆ Position the drip tray with the stainless steel grid (7) centrally in front of the appliance. Then push it gently forwards against the bowl until it engages in the operating position.

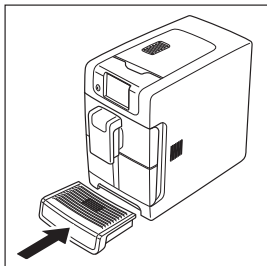

NOTE

- ▶ For the use of tall glasses for Latte Macchiato preparation please remove the drip tray .

4.4 Connecting the milk system

The milk system must be connected in order to dispense coffee specialities with milk/frothed milk. Proceed as follows:

- ◆ Open the door with the coffee outlet unit by pulling it up on the left side.

CAUTION

- ▶ Before opening or closing the door, always push the outlet unit into the upper position, otherwise the milk tube on the inside could become pinched off.

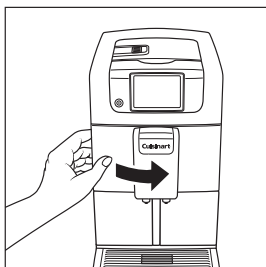

4 Putting into operation

- ◆ Insert the end of the milk tube that is cut at an angle into the top left opening of the milk frother 1 to the stop, and press the milk tube into guides 2 and 3.

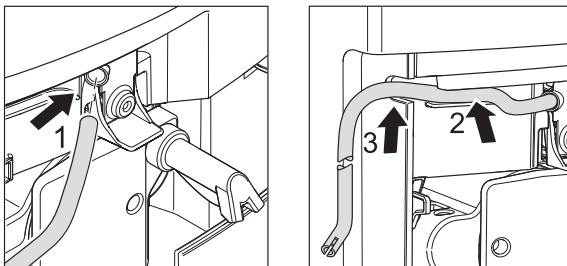

NOTE

- ▶ If you only wish to dispense hot water the hose may not be connected.

- ◆ Close the door with the coffee dispensing unit.

NOTE

- ▶ Before opening or closing the door, always push the outlet unit into the upper position, otherwise the milk tube on the inside could become pinched off.

- ◆ Place a milk container to the left of the coffee machine.
- ◆ Insert the milk hose into the opened milk container.

NOTE

- ▶ The tube end with the split end should reach all the way to the bottom of the milk container.
- ▶ In the case of newly opened, not yet completely filled milk container, it is possible that milk will drip out of the dispenser unit after preparation of a coffee speciality.

NOTE

- ▶ Milk is a sensitive foodstuff. Always pay attention to cleanliness when dealing with milk. Open milk containers with clean hands and tools to prevent germs from getting into the milk.

4 Putting into operation

4.5 Filling with water

CAUTION

Milk, mineral water or other liquids can damage the water tank or the coffee machine.

- ▶ Only fill the water tank with fresh, cold water.
- ▶ Observe the maximum filling level of 1.4 litres.
- ▶ During initial startup (or when the water tank was previously emptied completely), water intake can be slowed down. In this case, it is helpful to switch the device off and on again.

To fill the water tank, proceed as follows:

- ◆ Push the coffee dispensing unit (3) into the uppermost position.
- ◆ Remove the water tank (6) from the appliance.
- ◆ Fill the water tank with fresh water up to its maximum on the lower edge of the filling hole.

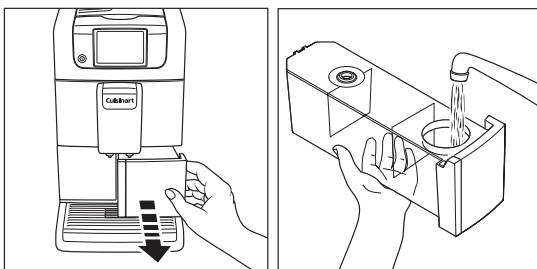

- ◆ Replace the water tank. Push it until it snaps in.

NOTE

- ▶ If the following warning appears on the display, the water tank must be topped up before the next drink is dispensed. Otherwise further function is not possible:



- ▶ Before inserting the water tank, make sure that it is dry on the outside. Wipe the water tank shaft dry also before inserting the water tank. See also section **7.2 Regular cleaning**.

4 Putting into operation

4.6 Filling the coffee bean container

NOTE

- ▶ Every coffee machine is thoroughly checked before delivery. Therefore, there may be residual ground coffee in the grinder. Your coffee machine is definitely new.

CAUTION

Damage to the grinding mechanism!

- ▶ Make sure that no foreign objects such as stones get into the coffee bean container. Damage caused by foreign objects in the grinder is excluded from the warranty.
- ▶ Fill the coffee bean container only with pure coffee beans without sugar coatings or aromatised constituents.

To fill the coffee bean container (10), proceed as follows:

- ◆ Fold back the lid of the coffee container.
- ◆ Fill the container with fresh coffee beans.
- ◆ Then close the container again.

NOTE

- ▶ If the following indication appears on the display, the bean container must be sufficiently full. Otherwise further function is not possible:



If this button is pressed, the process is continued.



If this button is pressed, the display changes back to the main menu.

5 Screen display with pressure-sensitive input area

The coffee machine is operated via the pressure-sensitive display. The corresponding function is triggered by pressing the graphical symbols on the display with the finger.

ATTENTION

It is possible to damage the pressure-sensitive surface of the display!

- ▶ Do not touch the display with sharp-edged objects.
- ▶ Avoid contamination. Instructions on cleaning the pressure-sensitive display can be found in section 7.2 *Regular cleaning*.

HINWEIS

- ▶ Some functions are only triggered when the graphical symbol is pressed for a longer period of time (3 sec.).

5.1 Main menu

In the main menu, the coffee machine uses either a tray or matrix representation. You can switch to any representation at any time.

In tray representation, the main menu is arranged as follows:

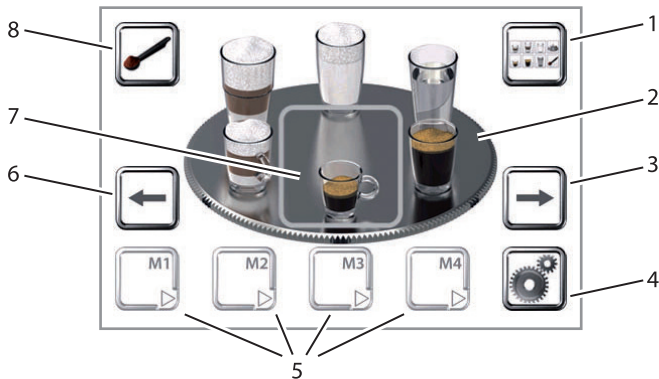

1	Switches to matrix representation	5	Memory locations 1 - 4
2	Product tray	6	Move selection left
3	Move selection right	7	Currently selected product
4	Call up settings menu	8	Operating with coffee grounds

5 Screen display

In matrix representation, the main menu is arranged as follows:

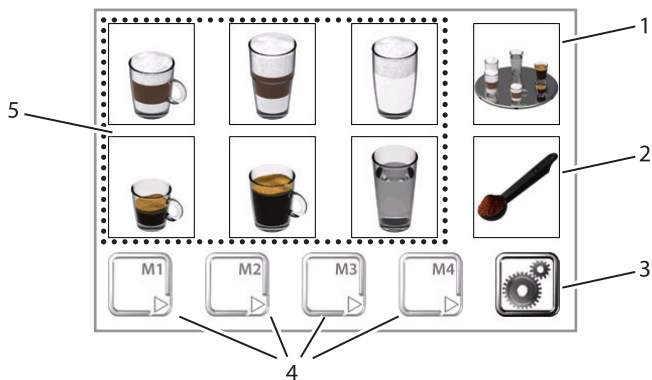

1	Switches to tray representation	4	Memory locations 1 - 4
2	Operating with coffee grounds	5	Product selection
3	Call up settings menu		

NOTE

- The previously-selected display type remains after switching off the coffee machine.

5 Screen display

5.2 Settings menu

In the settings menu  it is possible to make settings for the coffee machine and run various cleaning programmes.

The settings menu is arranged as follows:

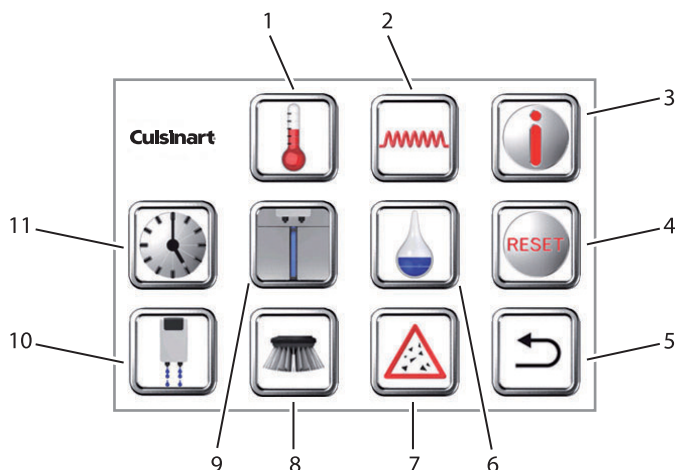

1	Temperature settings	7	Run descaling program
2	Set heating mode	8	Run cleaning program
3	Display information	9	Set water tank illumination
4	Reset to default settings	10	Clean milk system
5	Return to calling menu	11	Set timer
6	Set water hardness		

NOTE

- After 30 seconds, the display automatically jumps back to the main menu of the last-displayed view if no action takes place in the service menu.



5.3 Product symbols

The product symbols used in the menus have the following meaning:

	Cup of coffee		Espresso
	Cappuccino		Latte Macchiato
	Hot milk, Frothed milk		Hot water

5.4 Graphical symbols

The graphical symbols used in the menus have the following meaning:

	Confirm		Selects product on the left of the selection frame
	Cancels the action		Selects product on the right of the selection frame
	Back one menu level		Increase value
	Call coffee machine settings		Decrease value
	Call matrix menu		Switch between coffee grounds/coffee beans
	Prepare one cup		Prepare two cups
	Prepare a pot of coffee		Selection frame for product
	Free storage space (here memory location 1)		Allocated storage space; call saved settings (here memory location 1)
	Save as basic setting		Save current settings

5.5 Requirements on the user

All necessary actions for operating the coffee machine are prompted by the display. The following displays are possible during normal operation:

Refilling with water

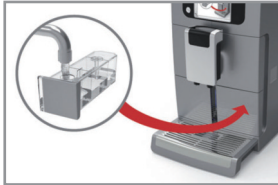

- ◆ Remove the water tank (7) and fill it as described in section 4.5 *Filling with water*.

Emptying the waste container



- ◆ Remove the waste container (5) and empty it as described in section 7.4 *Emptying the waste container*.

Milk system cleaning



- ◆ Clean the milk system as described in section 7.3 *Cleaning the milk system*.

Quick cleaning of the milk system after dispensing a milk drink



- ◆ Perform a quick milk system cleaning as described in section 6.12 *Milk system cleaning*.

6 Operation and use

Refill coffee bean container



- ◆ Fill the bean container (10) as described in section 4.6 *Filling the bean container*.

Close the bean container lid



- ◆ If the cover for bean container is opened during grinding, the grinder stops automatically. Close the lid for continuing.

NOTE

- ▶ Further coffee machine messages can be found in the section *8.2 Coffee machine messages, possible causes and remedies*.

6 Operation and use

This section contains important information on the operation and use of the coffee machine.

NOTE

- ▶ The settings described here refer to the tray representation display mode.

6.1 Safety precautions

⚠ WARNING

Observe the following safety precautions to avoid danger and material damage:

- ▶ Only operate the machine when the waste container, drip tray and the cup grate are fitted.
- ▶ Do not leave the coffee machine unsupervised during operation.

6.2 Switching on the coffee machine

NOTE

- ▶ Before switching on, always check that the water tank and the coffee bean container are full. Every time the coffee machine is switched on or off, it requires water for the automatic rinsing cycle.
- ▶ Small amounts of water can get into the waste container during each rinsing process. This is system-related and not a fault.

- ◆ Switch on the device by pressing the ① ON/OFF button and holding it down briefly.

During the heating procedure (approx. 30 seconds) the following display flashes:

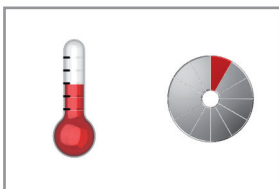

- ◆ When the operating temperature has been reached, the coffee machine automatically performs a rinse. The water flows into the drip tray.

The rinse is shown on the display:

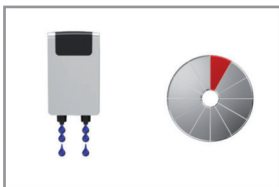

- ◆ When the rinse is completed, the coffee machine is ready for operation. The selection menu as previously set then appears on the display.



or

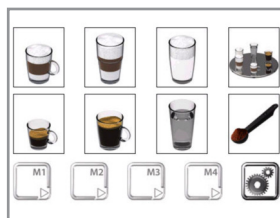

6.3 Switching off the coffee machine

- ◆ Press the ① ON/OFF button to switch off the coffee machine. It will then perform a rinsing cycle (if a drink was prepared before).

The following appears on the display:

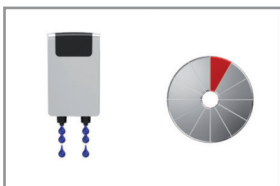

NOTE

- ▶ If you have also prepared a coffee speciality with milk/milk froth, the coffee machine will prompt you to also clean the milk system after rinsing. Details for this can be found in section **7.3 Milk system cleaning program**. Milk system cleaning should be carried out otherwise time-consuming cleaning of the milk frother will become necessary (see section **7.11 Cleaning the milk frother nozzle**).
- ▶ If the water tank is empty or the required milk system cleaning was not performed, the shut-off process will be delayed automatically for 15 minutes.

- ◆ The coffee machine subsequently prompts you to empty the waste container (5). The following appears on the display for 15 seconds (see also section **7.4 Emptying the waste container**):



ATTENTION

- ▶ Empty the waste container immediately after each use to prevent mould from building up.

The coffee machine automatically switches itself off after 15 seconds.

6.4 Switching off the coffee machine in an emergency



In the event of an emergency, you can switch off the coffee machine at any time during operation by pressing the **① ON/OFF** button **2 times**.

Exception: during the rinsing procedure when switching the coffee machine on/off.

6.5 Determining the water hardness

Before using the coffee machine for the first time, it should be set to the appropriate water hardness for your region. You can determine the water hardness with the help of the test strip (14) supplied with the coffee machine. Proceed as follows:

- ◆ Dip the test strip into cold tap water for 1 second and shake off the excess water. After approximately 1 minute, the water hardness can read from the pink-coloured areas.

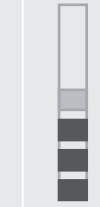
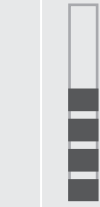
Water hardness	1 soft	2 medium-hard	3 hard	4 very hard
Test strip				

6.6 Setting and saving the water hardness level

To set the previously determined water hardness level, proceed as follows:

- ◆ Press the button in the main menu  (4).

The following appears on the display:

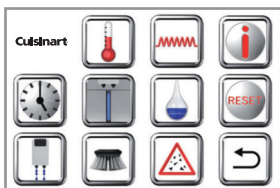

- ◆ Now press  to go to the menu for setting the water hardness.

The following appears on the display:

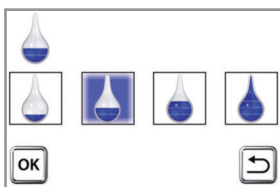

- ◆ Select the water hardness according to the value determined for your location. (Water hardness increases from the left (soft water) to right (hard water)).
- ◆ Confirm your input with  .

6.7 Setting the grinding fineness

You can set the the grinding fineness (11) with the help of the lever.

ATTENTION



Setting the grinding fineness when the grinder is not running can lead to damage!

- ▶ Only set the grinding fineness when the grinder is running.

To set the grinding fineness, proceed as follows:

- ◆ Place a cup under the coffee dispensing spout.
- ◆ In the main menu, press the symbol  to begin preparing coffee.
- ◆ Adjust the grinding fineness with the grinding fineness lever (11) **while** the grinder is running. The coffee is prepared and the grinding fineness is set.

The setting is implemented as follows:

	fine ground for "intensive taste"
	medium ground for "normal taste"
	coarse ground for "mild taste"

NOTE

- ▶ For light roasted coffee beans, set the grinding mechanism to "fine". If the grinding fineness is set too fine, the coffee will be dispensed a drop at a time.
- ▶ For dark roasted coffee beans, set the grinding mechanism to "coarse". If the grinding fineness is set too coarse, the coffee will be dispensed too quickly.
- ▶ Do not put your fingers into the bean shaft or the grinder of the coffee machine.

6.8 Changing the grinding quantity

NOTE



- ▶ The coffee machine is set for standard quantities for each cup size by default. If you wish to change the appropriate cup filling quantity permanently, refer to the instructions in the section **6.9 Changing the cup filling level**.

- ◆ Press the  symbol longer to select the menu for changing and saving the grinding quantity.



- ◆ Select the desired ground coffee quantity by pressing the coffee bean symbol.

The following selections are possible:

				
extra light	light	normal	strong	extra strong

NOTE

- ▶ An automatic grinding quantity correction measures the ground coffee quantity and adapts this gradually to the set value for the coffee strength. This compensates the differences between the grinder and various different coffee varieties. It may therefore be necessary to brew 5 times until the correction is perfect.
- ▶ The last-selected ground coffee quantity remains set for each cup size.
- ▶ The set ground coffee quantity remains stored even when the coffee machine is switched off.





6.9 Changing and storing the cup filling level

The coffee machine is set for standard quantities by default. However, you can set the cup filling level individually for each cup size.

NOTE

- ▶ In the case of the COFFEE CARAFE FUNCTION, it is not possible to change the cup quantity (4 oz per cup).

Proceed as follows:

- ◆ Press and keep pressing the button for the desired product until the option menu opens.
- ◆ Now set the desired strength of the coffee with the help of the coffee bean symbol on the left edge of the screen.
- ◆ The   buttons enable you to change the standard coffee quantity and set the individually desired quantity or cup size.
- ◆ By pressing  or  the brewing process starts with the preset changes.
- ◆ To save the settings **permanently**, refer to section **6.10 Changing and saving brewing settings**.

6.10 Changing and saving brewing settings



The coffee machine prepares coffee drinks and specialties according to preset standard values. These standard values as well as up to 4 individual saved options can be changed as required.

To do this, proceed as follows:

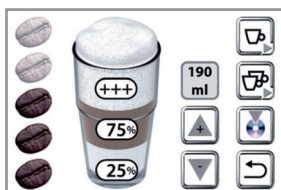
- ◆ Select a product in the main menu (in this example, Latte Macchiato), press and hold down the selection field of the product for approx. 3 sec. until for example, the following appears in the display:







6 Operation and use

- ◆ Press the coffee beans on the left edge of the screen to change the coffee strength.
- ◆ Press "+++" to change the froth quantity. the display changes from "-" to "+++".
- ◆ Pressing the percentage button changes the mixing proportion of milk and coffee.
- ◆ Press  or  to change the dispensed quantity. The display under the arrows indicates the selected quantity.
- ◆ Pressing the one or two cups selects the drink and brewing begins without saving.
- ◆ If you want save the settings press  to change to the memory view.

On the display, you now see for example:



- ◆ By pressing  You can save the settings as standard for every other drink of this product.
- ◆ Pressing a symbol from  to  saves the new settings only to the selected storage location, confirm with the  button. Press the  button to go up a level in the menu.

NOTE

- ▶ If a product setting is already saved to this memory location, it is replaced by the new setting.

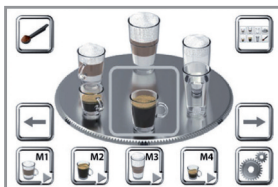

- ◆ Retrieve the settings by pressing the field of this memory location in the main menu.

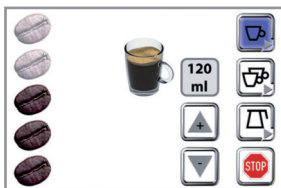

6.11 Changing a drink setting during selection

When you have selected a drink in the main menu (in this example, a cup of coffee) the following appears:



- ◆ You now have eight seconds to correct the filling quantity by pressing  or  and to select the grinding quantity by pressing the corresponding bean.

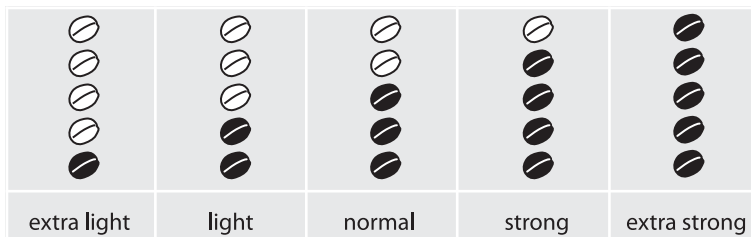

- ◆ Pressing the double cup or the jug selects the relevant function.
- ◆ Pressing a button each time increases the start of brewing by a further 3 seconds.

6.12 Milk system cleaning

Immediately after dispensing a milk drink you are prompted to clean the milk system. The following appears on the display:



NOTE

- ▶ It is for your own benefit to always carry out quick cleaning to prevent disturbances.
- ▶ If you are preparing more milky drinks or want to carry out the cleaning at a later time, press the Return button. In this case the instruction reappears every 5 minutes.

Remove the milk container, fill a receptacle with fresh water and insert the milk tube into the receptacle.

- ◆ Push the button  for starting the milk system quick cleaning program.

The water is fed into the appliance via the milk tube and discharged via the outlet unit into the drip tray. Alternatively it is possible to place a collecting container under the dispensing unit.



When quick cleaning is completed the display switch back to the main menu.

NOTE

- ▶ If quick cleaning has not been performed before the machine is switched off, you will again be prompted to carry out the quick cleaning. The machine cannot be switched off before quick cleaning has been carried out.
- ▶ Quick cleaning can only be skipped through the Auto-OFF mode.

If quick cleaning has been skipped via the Auto-OFF mode, the following image appears after switching the machine on again following the initial rinsing cycle, prompting you to clean the milk frother. (read section [7.11 Cleaning the nozzle of the milk frother](#)).



You will then be prompted to carry out a full milk system cleaning. This cannot be skipped. You can only dispense coffee again when cleaning has been performed. The following appears on the display:



- ◆ After that follow the instructions described in section [7.3 Milk system cleaning program](#).

6.13 Setting and storing the coffee temperature

You can select from 5 temperature levels. The coffee temperature levels are displayed as follows:

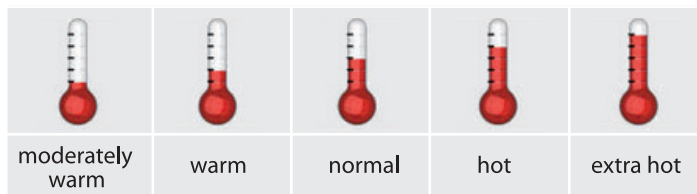

To set the coffee temperature, proceed as follows:

- ◆ Press the  button. The following appears on the display:

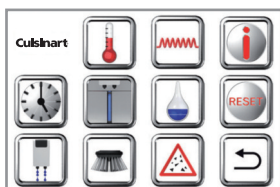

- ◆ Now press the  button.

The following appears on the display:

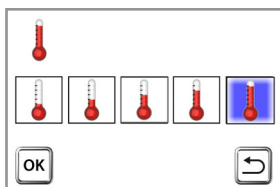

- ◆ Press the button to select the desired temperature setting according to the table.
- ◆ Confirm your input with the  button. The appliance returns to the setting menu automatically.

NOTE

- ▶ A pressed button is always highlighted in blue.
- ▶ To return to the setting menu without changing settings, press the  button or wait approx. 30 sec. until the coffee machine switches back to coffee mode automatically.



6.14 Select heating mode

By default, the heating system is programmed to save as much energy as possible (Ecomode) When switched on, the coffee machine heats up in this mode to the temperature required for preparation of the desired beverage. The heating then remains switched off until the next beverage is requested.

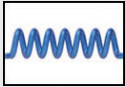
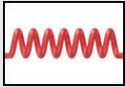
You can select one the following 2 settings:

	Ecomode (Heating system is only switched after a short wait when a drink is to be dispensed) Recommendation when used occasionally after longer periods of time between dispensing coffee.
	Standard mode (heating system switched on, preparation of coffee specialities after a short waiting time)

To set the heating system, proceed as follows:

- ◆ Press the  and then the  button.

The following appears on the display:

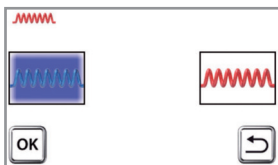

- ◆ Select the desired operating mode according to the table.
- ◆ Confirm your input with the  button. The appliance returns to the setting menu automatically.

NOTE

- ▶ A pressed button is always highlighted in blue.
- ▶ To return to the setting menu without changing settings, press the  button or wait approx. 30 sec. until the coffee machine switches back to coffee mode automatically.

6.15 Setting and storing the shut-off time

The appliance is programed for the highest possible saving of energy. The preset shut-off time is 9 minutes.

You can select from 5 shut-off times. The following shut-off times are possible:



To set the shut-off time, proceed as follows:

- ◆ Press the  and then the  button. The following appears on the display:

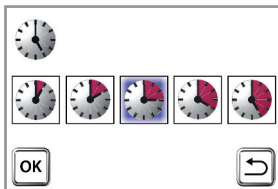

- ◆ Press the button according to the table to select the desired time span to automatic shut-off of the coffee machine.
- ◆ Confirm your input with the button . The appliance returns to the setting menu automatically.

NOTE



- ▶ A pressed button is always highlighted in blue.
- ▶ To return to the setting menu without changing settings, press the  button or wait approx. 30 sec. until the coffee machine switches back to coffee mode automatically.

NOTE

- ▶ The switch-off time always begins after pressing a button for the last time.

6.16 Setting the water tank illumination

The following settings are possible:

	Water tank illumination switched on
	Water tank illumination switched off

Please proceed as follows to set the water tank illumination:

- ◆ Press the  and then the  button. The following appears on the display:

The following appears on the display:

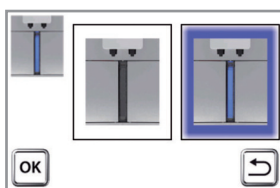

- ◆ Confirm your input with the button . The appliance returns to the setting menu automatically.

NOTE

- ▶ A pressed button is always highlighted in blue.
- ▶ To return to the setting menu without changing settings, press the  button or wait approx. 30 sec. until the coffee machine switches back to coffee mode automatically.

6.17 Resetting the coffee machine to the factory settings (Reset)

This function resets all previously changed values to their original factory settings.

The following settings and stored values are affected:

- Water hardness
- Cup filling quantity
- Ground coffee quantity
- Coffee temperature
- Shut-off time
- Heating system
- Water tank illumination
- Coffee quantity setting, milk-coffee proportion, froth quantity for coffee specialities and grinding quantity correction.

Performing a RESET deletes all the data of the save buttons.

To reset the coffee machine to the factory settings, proceed as follows:

- ◆ Press the  button.

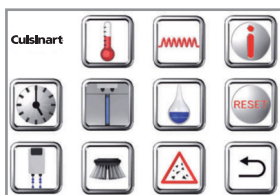

The following appears on the display:

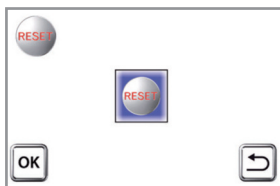

- ◆ Press the  button.

The following appears on the display:



- ◆ Press the "RESET" button in the middle of the screen.
- ◆ Confirm with  button.
- ◆ Press the  button to return to coffee mode.

6.18 Display number of dispensed coffees (Info menu)

To display the number of dispensed coffees to date, proceed as follows:

- ◆ Press the button  .

The following appears on the display:

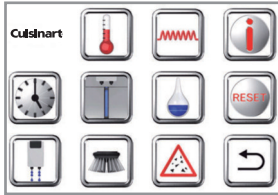

- ◆ Press the  button.

The following appears on the display:

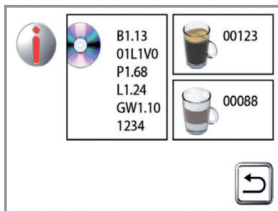

- ◆ The number of dispensed coffees is displayed on the top right.
- ◆ The number of dispensed coffee specialties can be seen on the image underneath.
- ◆ Press  **2 times** to return coffee mode, otherwise the display switches back to coffee mode automatically after 30 seconds.

6.19 Preparing coffee with whole coffee beans

To prepare coffee with whole coffee beans, proceed as follows:

- ◆ Place one or two cups under the coffee dispensing spout (4).
- ◆ In order to reduce heat loss and splashing, adjust the dispensing spout height to suit your cup size by moving it up or down.

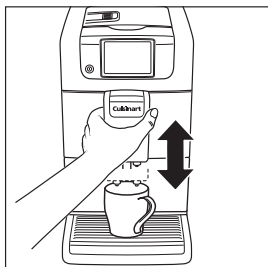

NOTE

- ▶ If the height adjuster is difficult to move, clean it. Refer to Chapter 7.5 *Removing and cleaning the coffee dispensing unit*.

- ◆ Briefly press the symbol  to select coffee preparation.



The grinding quantity, filling quantity as well as the number of cups can be changed during the first 3 seconds (pressing a button each time increases the duration by a further 3 seconds). After that, grinding begins.

6 Operation and use

During grinding, only the cup filling quantity can be changed.

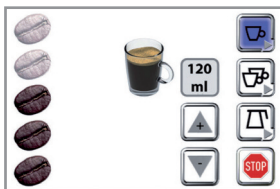

NOTE

- ▶ Please consider that two brewing processes are performed in sequence in two-cup operation. Only remove the cups when the all brewing processes are completed.
- ▶ During coffee preparation, the coffee powder is moistened with a small amount of water first for pre-brewing. The actual brewing process takes place after a short pause.
- ▶ You can stop coffee dispensing at any time, by pressing the  button.
- ▶ In the case of strongly uneven or only one-sided cup filling during 2-cup operation, check whether one or both coffee dispensing spouts are blocked on the inside by foreign matter (coffee bean or similar).

6.20 Coffee carafe function

NOTE

- ▶ The coffee carafe function is only possible via the coffee product option.
- ▶ Place a sufficiently large receptacle underneath the dispensing spout.

The appliance is set for cup quantity at the factory. However, you can set the coffee carafe function. Proceed as follows:

- ◆ Select the coffee product.

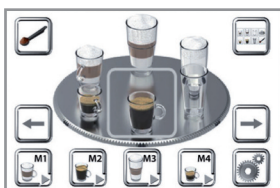

6 Operation and use

- ◆ Select the coffee carafe function  within 3 seconds.

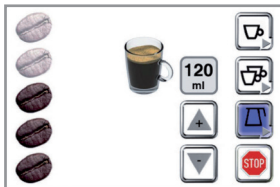

NOTE

- ▶ In the case of the COFFEE CARAFE FUNCTION, it is not possible to change the cup quantity (4 oz per cup).
- ◆ Now set the desired strength of the coffee with the help of the coffee bean symbol on the left edge of the screen.
- ◆ Decide whether 4, 6 or 8 cups are to be brewed. Press the corresponding button to begin brewing.
- ◆ You have 60 seconds to select the grinding quantity and the number of cups otherwise the appliance switches back to the main menu. After selecting the number of cups, you have 3 seconds to correct the grinding quantity or to switch to the 1- or 2-cup mode before grinding begins.



NOTE

- ▶ You can stop coffee dispensing at any time, by pressing the  button.
- ▶ After 4-cup, 6-cup or 8-cup mode finishes, please wait for 5 minutes before selecting 4-cup, 6-cup or 8-cup mode again.

6 Operation and use

6.21 Preparing coffee with coffee grounds

ATTENTION

- ▶ Ensure that you only use the measuring spoon supplied and never fill than the container with more than one level measuring spoon (max. 8 g) of coffee powder.
- ▶ Do not fill the shaft with water-soluble, freeze-dried instant products or other drink powders.
- ▶ Too finely ground coffee grounds can lead to faults.

To prepare coffee with coffee grounds, proceed as follows:

- ◆ Press the  button to select the "Coffee grounds" function.

The following appears on the display:

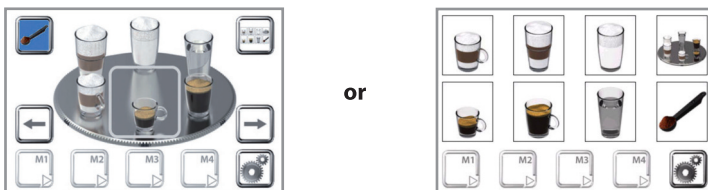

- ◆ Select a drink.

The following appears on the display:





- ◆ Open the lid of the coffee bean container (10) and the ground coffee chamber (9).
- ◆ Fill the powder shaft with a measuring spoon full of coffee grounds.

ATTENTION

- ▶ Ensure that grounds not clog the container and that no foreign matter gets into the container.
- ▶ Never fill the container with more than one level measuring spoon of coffee grounds.
- ▶ The filling container is not a storage container; the grounds must be transported directly to the brewing unit.



6 Operation and use

- ◆ Then close both lids again.
- ◆ By pressing you  return to the main menu. Press  to go to the drink setting.

Here it is possible to change the filling quantity within the 8 seconds before brewing begins.

NOTE

- ▶ During preparation of coffee, the "ground coffee quantity" function is deactivated. Therefore no information on the ground coffee quantity appears on the display.
- ▶ Only one cup can be prepared with coffee grounds.
- ▶ The milk and hot water functions cannot be selected in coffee grounds operation.

- ◆ Set the desired cup quantity by pressing the   buttons.
- ◆ Place a cup under the coffee dispensing spout.
- ◆ In order to reduce heat loss and splashing, adjust the height of the dispenser to suit your cup size by moving it up or down.

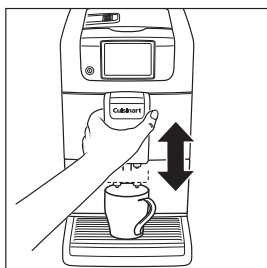

NOTE

- ▶ If height adjustment is stiff, see section *7.5 Removing and cleaning the coffee dispensing unit*.

NOTE

- ▶ You can stop coffee dispensing at any time, by pressing the



button on the display.

6.22 Hot water preparation



⚠ WARNING

Risk of scalding from hot splashing water!

Hot water from the steam nozzle can cause scalding.

- ▶ Avoid direct contact with the skin.

To prepare hot water, proceed as follows:

- ◆ Press the   buttons to select the "hot water" function.

The following appears on the display:



NOTE

- ▶ If the milk hose is connected, it must be disconnected from the milk frother nozzle before dispensing hot water. Otherwise milk could be sucked in unintentionally. See also section **4.4 Connecting the milk system**.

- ◆ Place a receptacle under the coffee dispensing spout.
- ◆ In order to reduce heat loss and splashing, adjust the height of the dispenser to suit your cup size by moving it up or down.

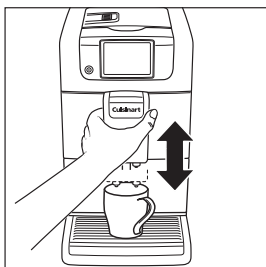

6 Operation and use

The coffee machine is set for standard quantities by default. You can set the cup filling level individually for each cup size. Proceed as follows:

- ◆ Press and hold down the "hot water" symbol.
- ◆ Press the   buttons to select the desired quantity.

NOTE

- ▶ To save the settings, proceed as described in section [6.10 Changing and saving brewing settings](#).

NOTE

- ▶ If the height adjuster is difficult to move, clean it. For this purpose, proceed as described in section [7.5 Removing and cleaning the coffee dispensing unit](#).

NOTE

- ▶ You can stop dispensing hot water at any time, by pressing the  button.

6.23 Preparing coffee specialities

The milk system must be connected in order to dispense coffee specialities. More information can be found in Chapter [4.4 Connecting the milk system](#).

You can prepare both "Latte Macchiato" and "Cappuccino" with your appliance. These differ primarily in the mode of preparation.

When "Latte Macchiato" is prepared, the frothed milk is output first into a tall glass and the coffee is added subsequently.

The reverse is the case when "Cappuccino" is prepared, first of all the coffee is poured into the cup, followed by the hot milk froth on top of the coffee.

NOTE

- ▶ Dispense hot water into the cups to heat them.
- ▶ Do not use soya or rice milk because good frothing results are not possible with these products.
- ▶ The milk type of milk used can influence the milk froth quality.

6 Operation and use





- ◆ Press the   buttons to select the function for a coffee specialty of your choice. The selected can be seen in the foreground.

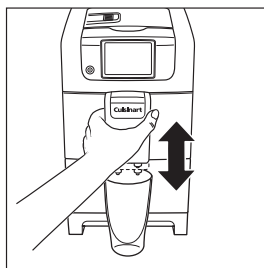
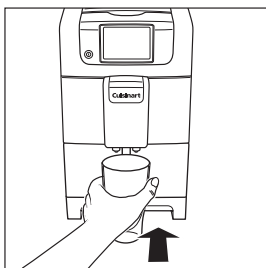

Image	Specialty
	Hot milk with froth
	Latte Macchiato
	Cappuccino

- ◆ Place a cup or glass under the coffee dispensing spout.

NOTE

- ▶ To prepare Latte Macchiato, first pull the drip tray (7) out of the appliance so that the taller Latte Macchiato glasses can fit under the coffee outlet.
- ◆ In order to reduce heat loss and splashing, adjust the dispensing spout height to suit your cup/glass size by moving it up or down.





6 Operation and use

NOTE

- ▶ If the height adjuster is difficult to move, clean it. Proceed as described in section 7.5 *Removing and cleaning the coffee dispensing unit*.

- ◆ Press the symbol on the display with your selected specialty to prepare it.
- ◆ As soon as coffee making starts, you can make the various settings such as coffee strength, milk quantity, froth quantity and overall quantity individually.







- ◆ By pressing the coffee bean symbol, it is possible to change the brewing strength of the drink.
- ◆ The milk froth quantity can be varied by pressing the "-" or "+++" symbols so that they are highlighted in colour.
- ◆ Pressing the percentage button changes the mixing proportion of milk and coffee.
- ◆ Use the  and  buttons it is possible to adjust the overall quantity of the drink to your desired cup size.
- ◆ Press the button  to prepare two drinks.

NOTE

- ▶ Be aware that two brewing processes are performed in sequence in two-cup operation. Put two cups next to each other under the dispensing spout. Only remove the cups when the both brewing processes are completed.
- ▶ If you wish to cancel prematurely during preparation of a coffee specialty, pressing the  button only stops milk preparation.
- ▶ The coffee machine has default factory settings. If you wish to change these settings, you will find instructions in section 6.10 *Changing and saving brewing settings*.

6 Operation and use

- ◆ Select the desired ground coffee quantity on the display. The following selections are possible:

				
extra light	light	normal	strong	extra strong

NOTE

- ▶ If you wish to cancel prematurely during preparation of a coffee speciality, pressing the  button only stops milk preparation.

After dispensing a coffee speciality with milk/froth, you are prompted to perform a quick milk system cleaning:



See also section **6.12 Milk system cleaning**

7 Cleaning and maintenance

This section contains important information on cleaning and maintenance of the coffee machine. Keep your coffee machine clean at all times to ensure a consistently high coffee quality and trouble-free function.

ATTENTION

Damage due to the effect of heat and aggressive cleaning agents.

All removable parts such as cup height adjustment, brewing unit, water container, waste container, milk frother, drip tray as well as the lid and bean container etc. are **not** suitable for the dishwasher.

- ▶ Clean the coffee machine according to the instructions as described in this section.
- ▶ Never soak the brewing unit and milk frother in descaling solution!

7.1 Safety precautions

⚠ WARNING

Observe the following safety precautions before starting to clean the coffee machine:

- ▶ Switch off the coffee machine and pull the plug out of the wall outlet before starting cleaning.
- ▶ Before cleaning, allow the coffee machine cool down.
- ▶ Do not use any scratching, abrasive or corrosive agents. Wipe the inside and outside of the housing with a soft damp cloth.
- ▶ Never immerse the coffee machine itself, the power cord or the mains plug into water or other liquids.
- ▶ Do not clean housing parts such as the waste container, water tank or drip tray in the dishwasher. Otherwise, the high-gloss surfaces will gradually become dull and matt.
- ▶ Never pour water into the coffee bean container or grinding mechanism as this could cause damage.
- ▶ Observe the cleaning and descaling instructions.

7.2 Regular cleaning

- Clean the outer surfaces of the appliance with a soft damp cloth, the display field can be cleaned e.g. with a lens cleaning cloth.
- Remove the waste container (5) and the water tank (6) and clean both with warm water and a mild washing-up liquid. Wipe both housings with a damp cloth.
- Empty the drip tray at regular intervals, but at least when the red filling level indicator becomes visible through the opening in the cup grate.
- Clean the drip tray with the cup grate (7) with warm water and a mild washing-up liquid.
- Wipe the coffee bean container with a dry lint-free cloth.

7.3 Milk system cleaning program

NOTE

- ▶ After dispensing a coffee speciality with milk/froth, you are prompted to perform a quick milk system cleaning
- ▶ If you are preparing more milky drinks or want to carry out the cleaning at a later time, press the Return button. In this case the instruction reappears every 5 minutes.
- ▶ If the machine stops automatically after dispensing one or more coffee specialities with milk froth, the instruction for milk system cleaning appears beforehand for 5 mins.
- ▶ If the milk system cleaning was not carried out before switching off via Auto-OFF, the machine prompts you to carry out a full milk system cleaning following the initial rinse after switching the machine on again.
- ▶ This cannot be skipped. You can only dispense coffee again when cleaning has been performed.
- ▶ A milk system cleaning solution can be bought in specialist shops.

The following appears on the display:



- ◆ Fill a receptacle with 8.5 oz of water and the appropriate quantity of cleaning solution for the milk system (Milk frother cleaning liquid can be purchased from Amazon).
- ◆ Insert the milk tube into the receptacle.

7 Cleaning and maintenance

NOTE

- ▶ The slanted end of the tube must reach the bottom of the receptacle.

Press the  button to start the cleaning program.

NOTE

- ▶ The cleaning solution is fed out of the receptacle via the milk tube and drained into the drip tray. Alternatively it is possible to place a collecting container (> 8 oz) under the dispensing unit.

The following appears on the display:



- ◆ The drip tray must now be emptied.
- ◆ Empty the receptacle with the cleaning solution, rinse it and fill it again with 8 oz of fresh water for rinsing.
- ◆ Insert the milk tube into the receptacle.

NOTE

- ▶ The slanted end of the tube must reach the bottom of the receptacle.

- ◆ Press the  button to start the rinsing program.

The water is fed out of the receptacle via the milk tube and drained into the drip tray. Alternatively it is possible to place a collecting container (> 8 oz) under the dispensing unit. The following appears on the display:

The following appears on the display:



The coffee machine performs a rinse which is completed automatically, on the display appears the main menu.

- ◆ The drip tray must now be emptied.

7.4 Emptying the waste container

The following appears on the display:

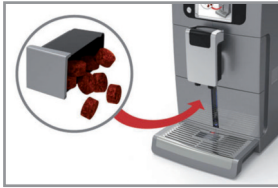

As soon as you are prompted to empty the waste container, no more coffee can be dispensed.

This display appears after a certain number of dispensed coffees. The number of possible dispenses depends on the various settings such as grinding fineness and quantity.

- ◆ Push the coffee dispensing unit (3) into the uppermost position.
- ◆ Pull the coffee grounds container out and clean the container thoroughly to prevent formation of mould. Insert the cleaned waste container back into the machine and push it until it stops.

The coffee machine is now ready to dispense coffee again.

NOTE

- ▶ Only empty the waste container when the coffee machine is switched on. The coffee machine can only detect emptying when it is switched on. If you empty the waste container with the coffee machine switched off, this will not be detected. This may result in prompting to empty after dispensing the first coffee when the coffee machine is switched on again the next time.
- ▶ Generally, the waste container should be cleaned daily if the coffee machine is used every day. You will be reminded of this each time by the following display symbol:



7.5 Removing and cleaning the coffee dispensing unit

To clean the coffee dispensing unit, proceed as follows:

- ◆ Push the coffee dispensing unit (3) into the uppermost position.
- ◆ Open the door with the coffee outlet unit by pulling it up on the left side.

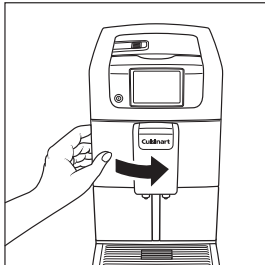

- ◆ Release the distribution hose on the door by pulling it lightly from the inside of the door towards the outside **2** and pressing to the left **3** so that it clicks out of the fastener. The dispensing unit can now be removed and the interior is easily accessible.

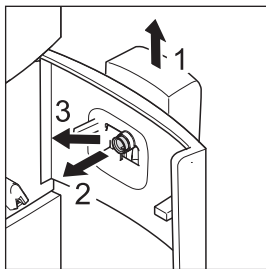

- ◆ Thoroughly clean the coffee dispensing unit from the inside and outside with warm water and a suitable brush to remove any coffee residue and prevent mould from forming.

NOTE

- ▶ Disconnect and clean the hose distribution system of the coffee dispensing unit (only if necessary, e.g. clogging), see section 7.6 *Cleaning the hose distribution system*.

- ◆ Reinsert the coffee dispensing unit again, see section 7.7 *Installing the coffee dispensing unit*.

7.6 Cleaning the hose distribution system

- ◆ Grip the loose hose end near to the spring and pull the cross-shaped hose connector **1** out of its fixing. Subsequently pull both hose ends with the sleeve ends out of the dispensing tubes **2**.

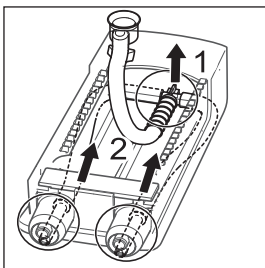

- ◆ Pull the sleeves out of the hoses **A** and disconnect the hoses from the connecting piece **C**. Pull the hose together with the spring **C** from the connecting piece.
- ◆ Leave the parts immersed in a milk cleaning solution for several hours. Refer to the instructions on the cleaning solution for the exact quantity.
- ◆ Subsequently clean the parts with the solution and rinse them thoroughly with clean water.
- ◆ Push the hoses onto the connecting piece **B** and the sleeves into the hoses **A**. Insert the hose with the spring push the hose and spring **C** up onto the connector **C**.

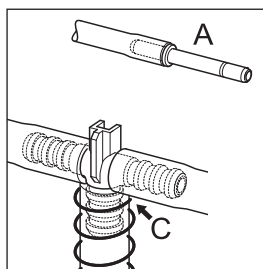
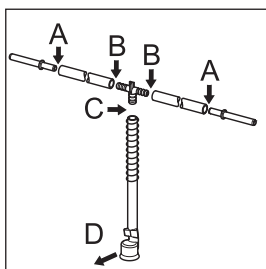

NOTE

- The spring must be evenly pulled over the half of the hose and the funnel-shaped end of the hose **D** must face upwards.

- ◆ Now insert both sleeve ends (with the hoses) into the dispensing tubes **2** and press them in until they snap in properly. Push the connecting piece into the fixing slot **1** and subsequently push the hoses to the right and left under the frame **3**.

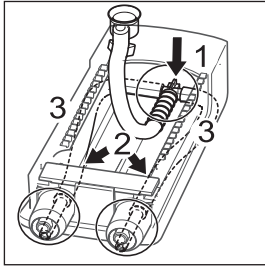

7.7 Installing the coffee dispensing unit

- ◆ Place the coffee dispensing unit in the upper position back into the door and push the unit slightly **1** so that it audibly snaps in once.

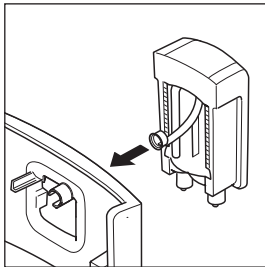

- ◆ Pull the hose from the inside through the door opening **2**, press it to the right into the holder **3** and push the funnel-shaped part of the hose back into the collar until it fits perfect

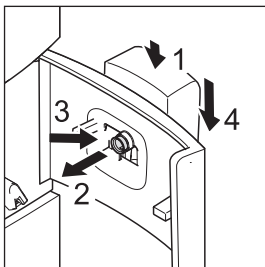

Now you can attach the coffee dispensing unit **4** and close the door. When closing the door, the dispenser should be located at the upper position, otherwise the milk tube will be jammed.

7.8 Cleaning the brewing unit

Clean the brewing unit every day. If you do not intend to use your coffee machine for a longer period of time (e. g., holidays), it is necessary to empty the waste container (5) and the water tank (6) and to clean the brewing unit thoroughly.

⚠ WARNING

Danger of burning!

The dispensing unit may still be hot if you have recently prepared coffee.

- ▶ Always allow the brewing unit to cool down before cleaning.

To clean the brewing unit, proceed as follows:

- ◆ Push the coffee dispensing unit (3) into the uppermost position.
- ◆ Open the door with the coffee outlet unit by pulling it up on the left side.

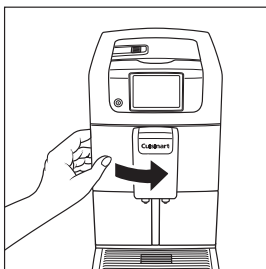

- ◆ Remove the coffee grounds container by pulling it out of the device.

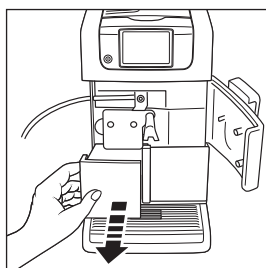

7 Cleaning and maintenance

ATTENTION!

Risk of breaking!

- ▶ Do not pull or carrying the brewing unit at his spout.

- ◆ Grip the lower front part of the brewing unit and pull it out to the front. Use your other hand to stop it from falling out.

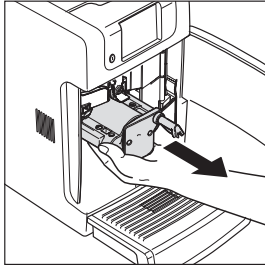

- ◆ Turn the brewing unit round. The brewing unit is open and the ejector folded down. The two stainless steel screens are now freely accessible.

NOTE

- ▶ If the brewing unit is closed, you can loosen it on the back with the help of the tool function on the measuring spoon (13). Push the toothed opening on the measuring spoon onto the pin and loosen it by turning completely at least 20 times.

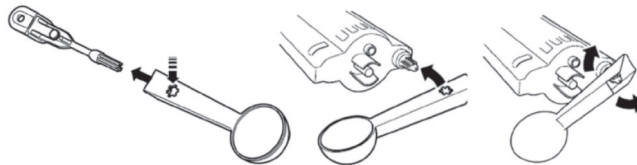

- ◆ Clean the opened brewing unit under warm running water. In particular, the stainless steel screens must be rinsed out well to remove any coffee residue. Also rinse out the three designated openings by filling in sufficient water to rinse out any accumulated coffee residue.

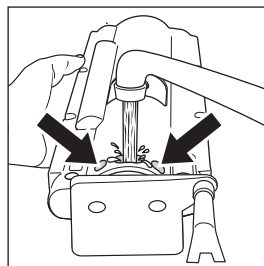
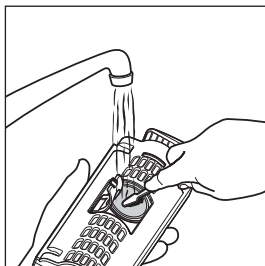

7 Cleaning and maintenance

- ◆ Soak the brewing unit from time to time (with constant use once a week) for approx. 30 minutes in hot water and a mild detergent. Shake the brewing unit lightly under water, then rinse all openings using a strong flow of water.
- ◆ Dry the brewing unit.
- ◆ Check if coffee powder shaft is clogged and clean if necessary.
- ◆ Replace the brewing unit by turning it into the right position (the outlet tube facing downwards and to the front), insert the brewing unit into the coffee machine.

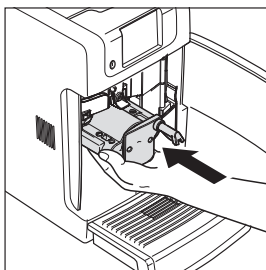

- ◆ Push the coffee grounds container back into the appliance and push the outlet unit into the upper position. Close the door.

NOTE



- ▶ You should only switch on the coffee machine when the brewing unit is fitted and the door with coffee dispensing unit is closed. After switching on, the brewing unit is adjusted and the normal heating process starts. During preparation of the first coffee after cleaning, an increased amount of water runs into the waste container.
- ▶ Before running the cleaning program, the metal sieves in the brewing unit must be clean and wiped dry.

7.9 Running the cleaning program

The cleaning program enables intensive cleaning of otherwise inaccessible areas. You should run the cleaning program regularly, however at the latest, when the following appears in the display:



Run the cleaning program as follows:

- ◆ In the main menu, press the  button.
- ◆ Now press the  button.
- ◆ Fill the water tank to the maximum filling height.
- ◆ Put a cleaning tablet* into the coffee grounds chamber (9).
- ◆ Follow the instructions and confirm by pressing the  button.

NOTE

- ▶ * Commercial cleaning tablets are available in most stores or online where espresso units are sold.
- ▶ The cleaning process takes approx. 8 minutes and should not be interrupted.
- ▶ In case of power failure during the cleaning program, it has to be restarted.
- ▶ Before running the cleaning program, the metal sieves in the brewing unit must be clean and wiped dry.

The cleaning water is collected in the drip tray. Alternatively, you can place a receptacle (>12 oz) under the spout. Only empty the receptacle when the coffee machine indicates that the drip tray must be emptied.

ATTENTION

Damage to the coffee machine and remnants left in the water by use of the wrong cleaner!

- ▶ Use only commercial cleaning tablets intended for fully automatic espresso machines. If other cleaning solutions are used, CUISINART assumes no liability for any damage caused.

As soon as the cleaning program is completed, the coffee machine is ready for operation and in the same state as the last-selected coffee mode.

- ◆ Remove the water tank and fill with fresh water. Insert the water tank again.
- ◆ Now prepare a cup of coffee and pour it away in the sink to eliminate any remaining residues of the cleaning tablet.

7.10 Running the descaling program

NOTE

- ▶ The frequency of descaling depends on the hardness of the water in your region. Therefore please do not forget to determine the water hardness and to set the corresponding hardness for the coffee machine! Please refer to sections **6.5 Determining the water hardness** and **6.6 Setting and storing the water hardness** for instructions on this.

The descaling program enables simple and effective descaling of your coffee machine. You should descale the coffee machine at regular intervals, but at least when the following symbol appears on the display:





ATTENTION

Damage to the coffee machine and remnants still in the water by use of the wrong descaler!

- ▶ Use only “Durgol Swiss Espresso” descaling solution. If other descaling solutions are used, CUISINART assumes no liability for any damage caused.
“Durgol” descaling solution is available from your local retailer, both online or in store.

To descale the coffee machine, proceed as follows:

- ◆ In the main menu, press the  button.
- ◆ Now press the  button.

The following appears on the display:



- ◆ Fill the water tank with 8 oz of water and 4 oz of Durgol descaling solution.
- ◆ Follow all further instructions on the display.

7 Cleaning and maintenance

NOTE

- ▶ The descaling process runs in 2 phases (phase 1: descaling process with descaling solution; phase 2: rinsing process with clear water), takes approx. 10 minutes and should not be interrupted..
- ▶ In the event of a power failure during descaling, the program has to be restarted!

⚠ WARNING

Irritation to skin or eyes can occur if they come into contact with the descaling solution!

- ▶ Avoid skin and eye contact.
- ▶ Rinse off descaling solution with clean water. Obtain medical advice after eye contact.

ATTENTION

Scaling residue can cause long-term damage to the brewing unit and the housing surface!

- ▶ It is imperative that you rinse the brewing unit thoroughly after every descaling process.
- ▶ Remove any splashes immediately.

NOTE

- ▶ During the descaling program, the water runs into the drip tray via the coffee spout. Alternatively, you can put a receptacle (> 12 oz) under the spout. Empty the receptacle when the it is indicated in the display that the drip tray needs to be emptied.

- ◆ After the descaling process (phase 1), empty the drip tray or the collecting receptacle as indicated in the display.



- ◆ Press the drip tray back onto the appliance until it audibly engages.

7 Cleaning and maintenance

- ◆ Rinse the water tank thoroughly and fill it with fresh water.



- ◆ Put the water tank back into the coffee machine and press  .

The rinsing process (phase 2) starts.

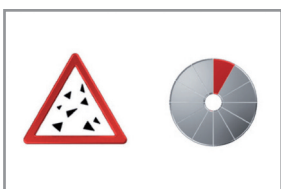

After completing the rinsing process (phase 2), empty the drip tray or the collecting receptacle and press "OK". You will now be prompted to remove and clean the brewing unit.



- ◆ Clean the brewing unit as described in section **7.8 Cleaning the brewing unit**.
- ◆ Reinsert the brewing unit and close the door. Following that, the brewing unit is adjusted automatically and the coffee machine switches back to normal operating mode.

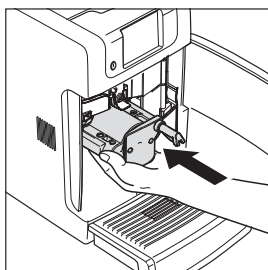

7.11 Cleaning the nozzle of the milk frother

If you do not perform milk system cleaning within a given time after preparing milky drinks, you will be prompted by the following image to clean the nozzle of the milk frother.



- ◆ After that confirm with the  button.

To clean the the nozzle of the milk frother, proceed as follows:

- ◆ Push the coffee dispensing unit (3) into the uppermost position.
- ◆ Open the door with the coffee outlet unit (3) by pulling it up on the left side and pull the milk hose out of the milk frother.

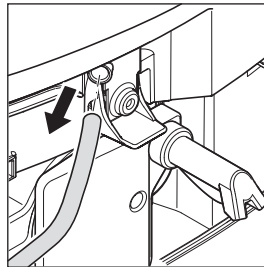
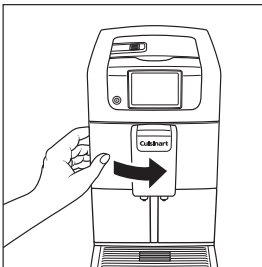

- ◆ Fold the lever on the milk frother upwards and pull the milk frother out towards you.
- ◆ Clean both openings with a thin needle or with a thin brush (e.g. with a dental brush or the brush of the measuring spoon). Make sure that the openings are completely free after cleaning.

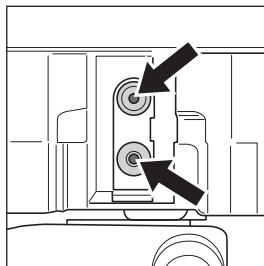
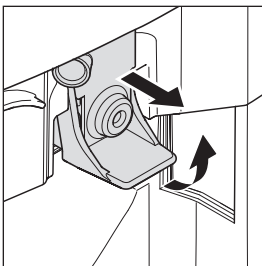

7 Cleaning and maintenance

- ◆ Remove the lid (1) from the milk frother
- ◆ Remove the milk frother nozzle from the milk frother by inserting the rounded end of the measuring spoon into the slot of the milk frother nozzle and turning 45° to pull it out. The nozzle is lifted up slightly during turning so that it can be removed more easily.

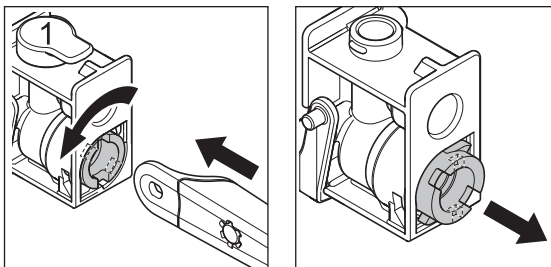

- ◆ Clean the milk frother nozzle with a thin needle or with a thin brush (e.g. with a dental brush or with the brush of the measuring spoon). Pay attention that the opening is completely free after cleaning.

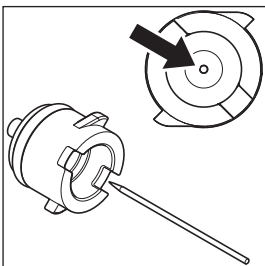

- ◆ Subsequently use the brush of the measuring spoon to clean all parts of the milk frother nozzle. Make sure that all vents of the milk frother and its nozzle are cleaned with the brush.

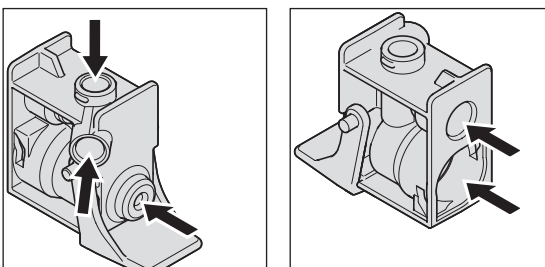

- ◆ For removing tough soiling mix 6.15 oz of warm water with the corresponding quantity of milk cleaning solution. Refer to the instructions on the cleaning solution for the exact quantity.

- ◆ Leave all parts of the milk frother in the cleaning solution for 5 hours or over night.
- ◆ Replace the frother nozzle in the milk frother and lock the nozzle by turning it 45° with the rounded end of the measuring spoon.

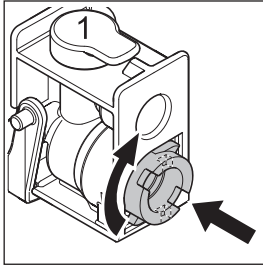

- ◆ Replace the lid 1 (pay attention to the direction).
- ◆ Replace the milk frother in the coffee machine and push the lever downwards to lock.

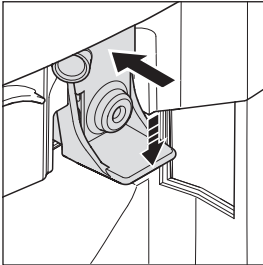

- ◆ Insert the end of the milk hose into the opening on the upper left of the milk frother until it stops and press the milk hose into the guide.

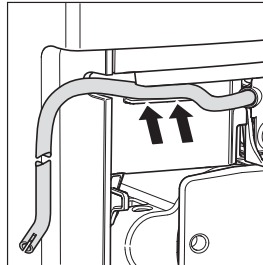
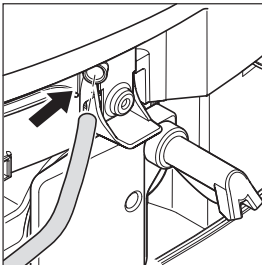

- ◆ Close the door of the coffee dispensing unit. When closing the door, the dispenser should be located at the upper position, otherwise the milk tube will be jammed.

8 Troubleshooting

This section contains important information on localising and eliminating faults.

Please observe the notes to prevent danger and damage.

8.1 Safety precautions

DANGER

Danger from electric current!

- ▶ Pull the mains plug out of the plug socket before beginning with troubleshooting.

WARNING









Danger from unqualified repairs!

Observe the following safety precautions to avoid danger and material damage:







- ▶ Do not open the coffee machine. Repairs to electrical coffee machines may only be carried out by qualified electricians. Unqualified repairs can lead to considerable danger for the user and cause serious damage to the coffee machine.

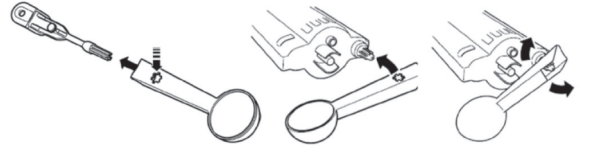

8 Troubleshooting

8.2 Coffee machine messages, possible causes and remedies

Display	Cause	Remedy
	<ul style="list-style-type: none"> Water tank is empty 	<ul style="list-style-type: none"> Fill water tank: see section 4.5 Filling with water.
	<ul style="list-style-type: none"> Waste container is full. 	<ul style="list-style-type: none"> Empty and clean the waste container: see section 7.4 Emptying the waste container.
	<ul style="list-style-type: none"> Waste container is missing. 	<ul style="list-style-type: none"> Fit waste container.
	<ul style="list-style-type: none"> Brewing unit is missing. 	<ul style="list-style-type: none"> Install brewing unit.
	<ul style="list-style-type: none"> No beans in the container. 	<ul style="list-style-type: none"> Fill the bean container with beans.
	<ul style="list-style-type: none"> Number of dispensed coffees prompts cleaning 	<ul style="list-style-type: none"> Run the cleaning program: see section 7.9 Running the cleaning program
	<ul style="list-style-type: none"> Number of dispensed coffee prompts descaling 	<ul style="list-style-type: none"> Run the descaling program: see section 7.10 Descaling program.
	<ul style="list-style-type: none"> Process aborted due to malfunction or incorrect operation 	<ul style="list-style-type: none"> Machine goes to normal standby function.

8 Troubleshooting



Display	Cause	Remedy
	<ul style="list-style-type: none"> Brewing unit is blocked (technical reason) 	<ul style="list-style-type: none"> Pull out the brewing unit and loosen it on the rear side using the tool function of the measuring spoon (13). Push the toothed opening on the measuring spoon onto the pin and loosen it by turning completely at least 20 times. Then thoroughly rinse out the brewing unit.
		
	<ul style="list-style-type: none"> Coffee temperature is faulty. 	<p>If this message appears on the display, turn off the coffee machine.</p>
	<ul style="list-style-type: none"> Error in motor valve. 	<p>Switch on the machine again after a cooling-down period of approx. 30 minutes.</p>
	<ul style="list-style-type: none"> Main switch blocked. 	<p>If the message is displayed again, an error has occurred that requires technical assistance.</p>
	<ul style="list-style-type: none"> Cleaning the brewing unit: see section 7.8. 	<p>Contact us via the free service hotline:</p> <p style="text-align: center;">1 - 800 - 726 - 0190</p>
	<ul style="list-style-type: none"> Error in input voltage. 	<p>If it is not possible to obtain help on the telephone, you will be instructed on the further procedure.</p>
	<ul style="list-style-type: none"> Communication failure. 	

Display	Cause	Remedy
	<ul style="list-style-type: none"> Grinding fineness set too fine or coffee grinds used is too fine. 	<ul style="list-style-type: none"> Set grinding fineness coarser or use a different, coarser coffee grinds.
	<ul style="list-style-type: none"> The water tank has overflowed or is too wet. 	<ul style="list-style-type: none"> Dry the water tank and the water tank compartment thoroughly.
	<ul style="list-style-type: none"> Water tank lid is missing. 	<ul style="list-style-type: none"> Remove the water tank and put on the lid.
	<ul style="list-style-type: none"> Too much air in the system. 	<ul style="list-style-type: none"> Top up the water tank.
	<ul style="list-style-type: none"> Coffee shaft is blocked by coffee grinds. 	<ul style="list-style-type: none"> Take out the brewing unit, clean the coffee shaft by pushing a suitable (round) brush through the grinds opening from above.
	<ul style="list-style-type: none"> Grinding mechanism clogged by foreign matter. 	<ul style="list-style-type: none"> Empty the bean container, turn the grinder anticlockwise by its cover and vacuum the bean container thoroughly.
	<ul style="list-style-type: none"> Lid of bean container is opened during grinding. 	<ul style="list-style-type: none"> Close the lid.

8.3 Problems, possible causes and remedies

Problem	Cause	Remedy
Espresso/coffee not hot enough	<ul style="list-style-type: none"> ● Cups too cold. 	<ul style="list-style-type: none"> ● Warm up cups with hot water. ● Increase the coffee temperature: see section 6.13.
Espresso/coffee too weak.	<ul style="list-style-type: none"> ● Not enough ground coffee used. 	<ul style="list-style-type: none"> ● Measure coffee properly: top up with max. 1 measuring spoon of coffee beans. ● Set ground coffee quantity higher. ● Vary grinding fineness. ● Try a different coffee sort.
	<ul style="list-style-type: none"> ● Ground coffee chamber clogged. 	<ul style="list-style-type: none"> ● Unclog ground coffee chamber with spoon handle or similar object.
	<ul style="list-style-type: none"> ● Coffee type changed, setting changed. 	<ul style="list-style-type: none"> ● Take the automatic grinding quantity correction into consideration: see section 6.8 under Notes.
Very loud noise during grinding.	<ul style="list-style-type: none"> ● Grinding mechanism clogged by foreign matter. 	<ul style="list-style-type: none"> ● Send the coffee machine to CUISINART customer service for inspection. ● The coffee machine can still be operated with ground coffee.
	<ul style="list-style-type: none"> ● Grinding mechanism clogged by coffee grinds. 	<ul style="list-style-type: none"> ● Unclog ground coffee chamber with spoon handle or similar object.
No milk froth or milk not dispensed.	<ul style="list-style-type: none"> ● Milk system not correctly connected. 	<ul style="list-style-type: none"> ● Check milk system connection: see section 4.4, 7.6 and 7.7.
	<ul style="list-style-type: none"> ● Milk frother is not completely inserted. 	<ul style="list-style-type: none"> ● Checking the milk frother: see section 7.11.
	<ul style="list-style-type: none"> ● Milk tube bent. 	<ul style="list-style-type: none"> ● Relocate the milk hose: see section 7.6.
	<ul style="list-style-type: none"> ● Milk container is empty. 	<ul style="list-style-type: none"> ● Fill milk container.
	<ul style="list-style-type: none"> ● Milk system clogged. 	<ul style="list-style-type: none"> ● Clean froth nozzle: see section 7.11.
	<ul style="list-style-type: none"> ● Steam outlet of the coffee machine is blocked. 	<ul style="list-style-type: none"> ● Descaling the coffee machine: see section 7.10.

8 Troubleshooting

Problem	Cause	Remedy
Low quality froth.	<ul style="list-style-type: none"> • Milk too warm, too old or fat content too high. 	<ul style="list-style-type: none"> • Use cold, low-fat milk.
	<ul style="list-style-type: none"> • Froth nozzle is dirty. 	<ul style="list-style-type: none"> • Clean froth nozzle: see section 7.11.
	<ul style="list-style-type: none"> • Milk system is dirty. 	<ul style="list-style-type: none"> • Clean milk system: see section 7.3.
	<ul style="list-style-type: none"> • Steam outlet of the coffee machine is blocked. 	<ul style="list-style-type: none"> • Descaling the coffee machine: see section 7.10.
Display shows "Water tank empty" even though the tank is full 	<ul style="list-style-type: none"> • Air in system. 	<ul style="list-style-type: none"> • Dispense a little hot water: see section 6.22.
	<ul style="list-style-type: none"> • Water tank walls and shaft contaminated with limescale. 	<ul style="list-style-type: none"> • Clean inner and outer walls of water tank and the inner wall of the water tank shaft with a brush and descaling solution.
	<ul style="list-style-type: none"> • Water system clogged. 	<ul style="list-style-type: none"> • As a precautionary measure, run the cleaning or descaling program: see sections 7.9. and 7.10
"Water tank is empty" does not appear in the display despite an empty water tank. 	<ul style="list-style-type: none"> • Too much moisture in the water tank shaft. 	<ul style="list-style-type: none"> • Remove water tank and dry off thoroughly. Dry the water tank shaft thoroughly on the inside.
	<ul style="list-style-type: none"> • Waste container was emptied while the coffee machine was switched off. 	<ul style="list-style-type: none"> • Empty the waste container only when the coffee machine is switched on.
"Empty waste container" is displayed too early. 	<ul style="list-style-type: none"> • Waste container was emptied while the coffee machine was switched off. 	<ul style="list-style-type: none"> • Empty the waste container only when the coffee machine is switched on.

8 Troubleshooting

Problem	Cause	Remedy
Water in the waste container.	<ul style="list-style-type: none"> Water leaks into the waste container during each rinsing process. 	<ul style="list-style-type: none"> No remedy necessary (technical reasons).
Coffee dispensing too slow.	<ul style="list-style-type: none"> Grinding fineness set too fine. 	<ul style="list-style-type: none"> Set coarser grinding fineness.
	<ul style="list-style-type: none"> Grinding quantity set too high. 	<ul style="list-style-type: none"> Set ground coffee quantity lower.
	<ul style="list-style-type: none"> Water system clogged. 	<ul style="list-style-type: none"> Run the descaling program.
Water runs into the waste container during rinsing when switching the coffee machine on and off.	<ul style="list-style-type: none"> Brewing unit is blocked or maladjusted. 	<ul style="list-style-type: none"> Adjust the brewing unit. See also 
Coffee machine cannot be switched on.	<ul style="list-style-type: none"> Mains plug not plugged in. 	<ul style="list-style-type: none"> Plug the mains plug in.
Coffee dispensing is very uneven or only one-sided.	<ul style="list-style-type: none"> Spout is clogged or blocked by foreign matter (e.g., coffee bean or similar). 	<ul style="list-style-type: none"> Pull the coffee spout upwards and clean the inside or remove the foreign matter (e.g., coffee bean). See section 7.5. Removing and cleaning the coffee dispensing unit
Coffee is very watery or only hot water.	<ul style="list-style-type: none"> Coffee shaft is blocked by coffee grounds. 	<ul style="list-style-type: none"> Remove the brewing unit. Clean the coffee shaft by pushing a suitable (round) brush through the ground coffee chamber opening.

NOTE

- ▶ If you cannot resolve the problem with the steps described above, please contact customer service.
- ▶ The free service hotline number: **1-800-726-0190**

8.4 Proper packing of the coffee unit

In the event of a warranty claim, pack the coffee machine into the original carton using the original packing material and proceed as follows:

- ◆ Empty the water tank (6), waste container (5), drip tray (7) and the coffee bean container (10). Clean the coffee machine and all parts. Insert the water tank and the waste container back into the coffee machine. Pack the coffee machine and the drip tray each into a plastic bag.
- ◆ Put the lower styrofoam tray into the box. Place the coffee machine and the tray into the box, wrap the the connecting cable and insert it into the prescribed styrofoam tray.

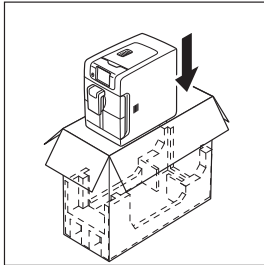

- ◆ Place the upper styrofoam tray on top so that the coffee machine is so sitting correctly in its prescribed tray. Lay the drip tray in the prescribed tray and close the box.

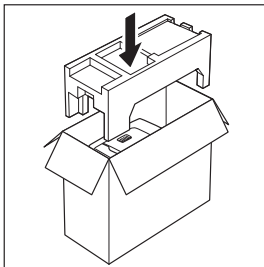

- ◆ Finally seal the carton with adhesive tape!

9 Storage

If you do not intend to use the coffee machine for a prolonged period, clean it as described in section 7 *Cleaning and maintenance* in order to prevent mould from building up. Mould is harmful to health. Store the coffee machine and all accessory parts in a dry, clean and frost-free place which is protected against direct sunlight.

10 Disposal



This symbol on the product, the operating instructions or the packaging indicate that this product must not be disposed of as normal household refuse after the end of its service life. Dispose of the coffee machine in accordance with the EC Directive 2012/19/EC-WEEE (Waste Electrical and Electronic Equipment). Should you have any questions, please contact the local authority responsible for waste disposal.

The materials can be recycled in accordance with their markings. Proper recycling and disposal of the coffee machine and its materials after the end of its service life makes a major contribution to the protection of our environment.

NOTE

- ▶ Use the collection point at your place of residence to return and recycle old electrical and electronic coffee machines. Ask your local authority where the responsible disposal point is located.
- ▶ Make the coffee machine unserviceable before disposal. Keep your old coffee machine away from children until it is collected.

10.1 Disposal of the packaging

The packaging protects the coffee machine against damage during transit. The packaging materials have been selected according to environmental and waste disposal aspects and can therefore be recycled.



Returning the packaging to the material cycle saves raw materials and reduces the amount of waste generated. When no longer required, dispose of the packaging materials in accordance with the local regulations.

NOTE

- ▶ The packaging protects the appliance against transport damage. Keep the original packaging of the appliance as long as necessary so that it can be correctly and securely packed in case repairs are required.

11 Appendix

11.1 Technical data

Designation	Auto-Cappuccino automatic coffee machine
Order No.	EM-1000
Operating voltage	120 VAC / 60 Hz
Power consumption	approx. 1450 W
Heating system	Thermoblock continuous-flow heater, approx. 1400 W
Pump	High-performance electromagnetic pump; Pressure: max. 15 bar
Power cord	max. 43 in.
Dimensions	13.7 x 7.8 x 16.0 mm (H x W x D)
Water tank	48 oz
Weight	approx. 23 lbs
Protection class	N/A

Interference suppression:

This coffee machine is interference-suppressed in accordance with the interference suppression directives.

11.2 Warranty

We guarantee a 3-year warranty for our coffee machines in accordance with the statutory provisions of the country in which the coffee machine was purchased.

This applies to all faults caused by material or manufacturing defects.

This warranty does not cover:

- Parts subject to wear such as seals, valves or the grinding ring and cone.
- Damage caused by failure to comply with the required cleaning and descaling intervals.
- Damage caused by the use of other cleaning or descaling solutions than those recommended by the manufacturer.
- Coffee machine used other than for normal purposes in the private household, e.g. for commercial purposes or use on public or commercial premises.
- Coffee machines not used for the intended purpose or not put into operation as stated in the operating instructions, e. g. filled with any other liquid other than clear water, the use of candied beans, foreign matter in the coffee bean container etc.
- Coffee machines opened and/or manipulated by unauthorised persons.

Damaged parts excluded from the warranty or those parts subject to wear will be replaced/repared by your CUISINART Service department against refund of the costs.

The warranty period begins with the original date of purchase. Claims can only be made under warranty if the original invoice or proof of purchase is submitted with the defective coffee machine.

Claims made under warranty do not prolong the statutory warranty period.

